

# E436 SC15-NM Board

## Host Connector and SC15 Host block

- CHANGES FOR A01
- 1) DPD Pull up powered from HVDD\_C - for accurate Leakage current measurements on HVDD power
  - 2) Resistor divider to generate EMVREF moved to EMU\_1 for accurate current measurements on EMVDD rail
  - 3) Removed regulator U3 and associated components which generated RESERVE\_1 voltage which was not used

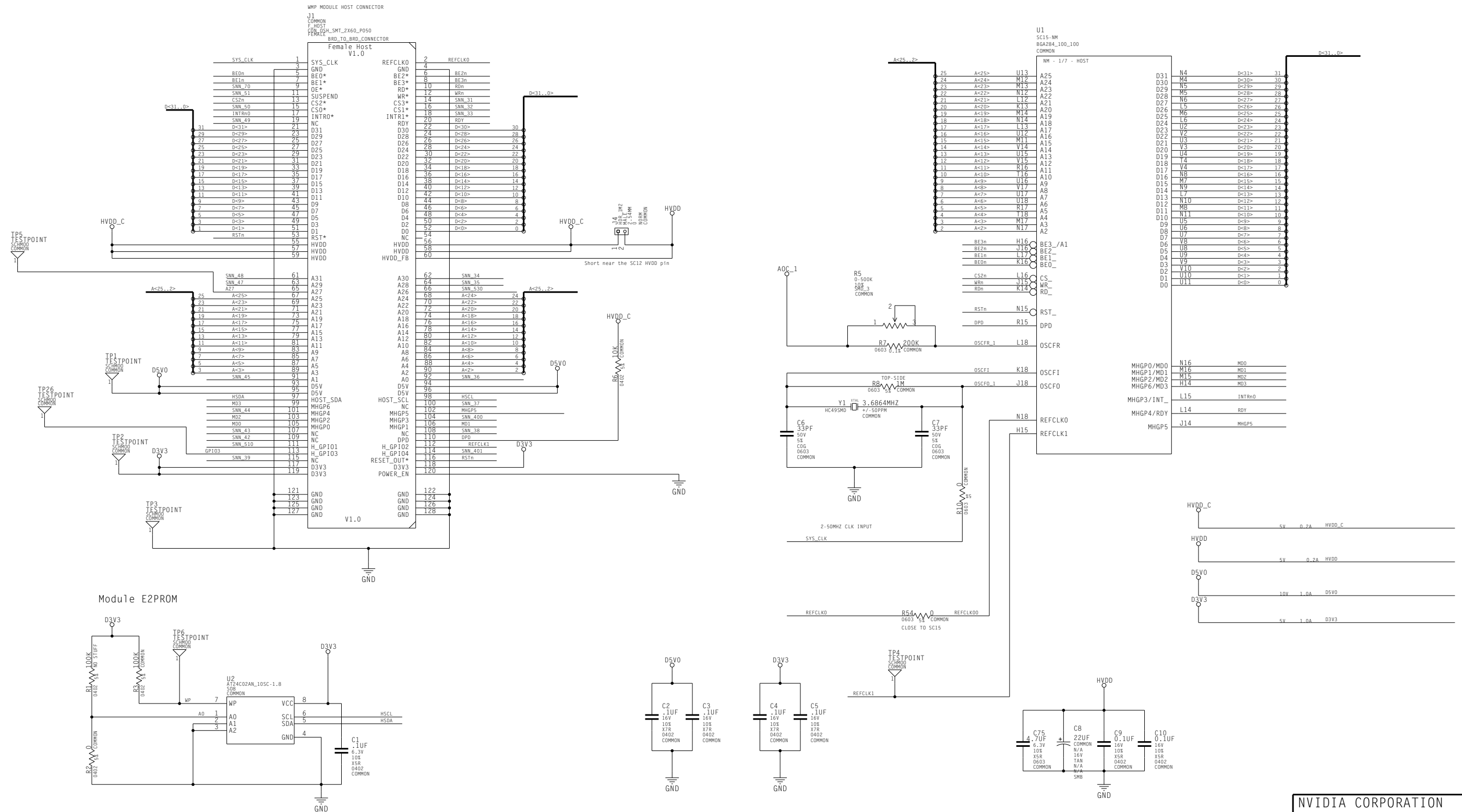

**NVIDIA CORPORATION**  
 2701 SAN TOMAS EXPRESSWAY  
 SANTA CLARA, CA 95050, USA

ASSEMBLY: BASE LEVEL GENERIC ONLY, COMMON & NO\_STUFF ASSEMBLY NOTES AND BDM NOT FINAL  
 PAGE: DETAIL

NV_PN	600-80436-0000-100
ID	e436
NAME	manoharc
PAGE	1 OF 5
DATE	23-AUG-2005

ALL NVIDIA DESIGN SPECIFICATIONS, REFERENCE BOARDS, FILES, DRAWINGS, DIAGNOSTICS, LISTS AND OTHER DOCUMENTS OR INFORMATION (TOGETHER AND SEPARATELY, "MATERIALS") ARE BEING PROVIDED "AS IS". THE MATERIALS MAY CONTAIN KNOWN AND UNKNOWN VIOLATIONS OR DEVIATIONS OF INDUSTRY STANDARDS AND SPECIFICATIONS. NVIDIA MAKES NO WARRANTIES, EXPRESSED, IMPLIED, STATUTORY OR OTHERWISE WITH RESPECT TO THE MATERIALS OR OTHERWISE, AND EXPRESSLY DISCLAIMS ALL IMPLIED WARRANTIES INCLUDING, WITHOUT LIMITATION, THE WARRANTIES OF DESIGN, OF NON-INFRINGEMENT, MERCHANTABILITY OR FITNESS FOR A PARTICULAR PURPOSE, OR ARISING FROM A COURSE OF DEALING, TRADE USAGE, TRADE PRACTICE, OR INDUSTRY STANDARDS.



# E436 SC15-NM Board

## Audio SDCARD & Test Interfaces

### SC15 Audio I2S & AC97

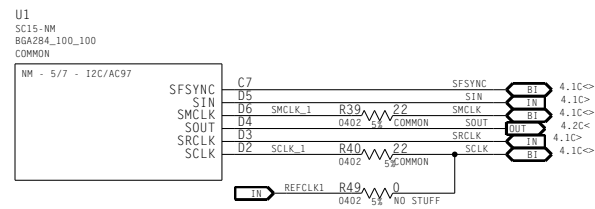

### SC15 JTAG & SDCARD

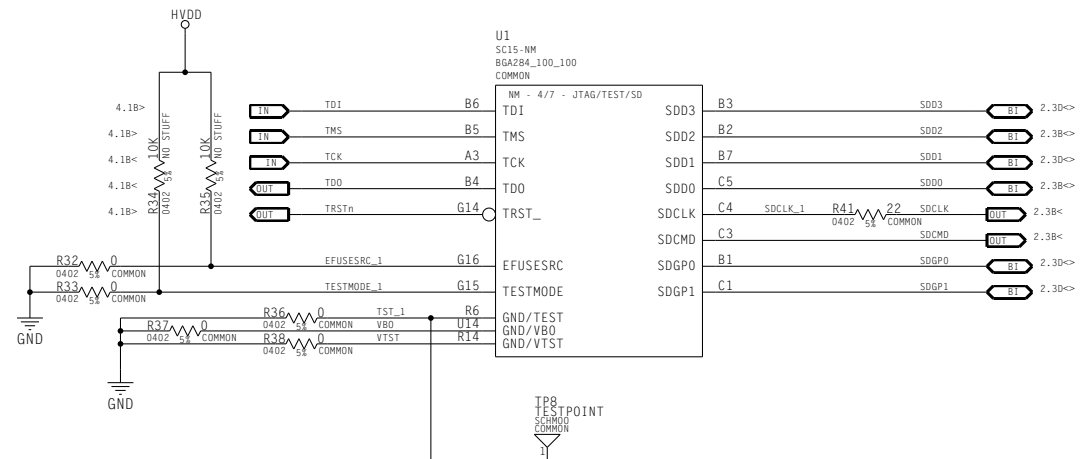

### SC15 Stacked Chip Test header

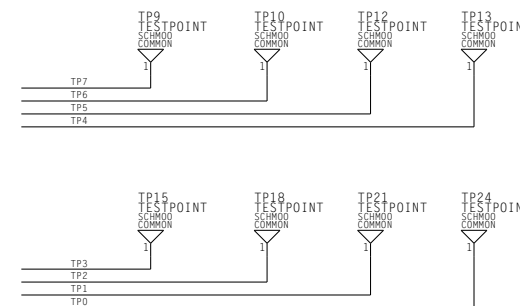
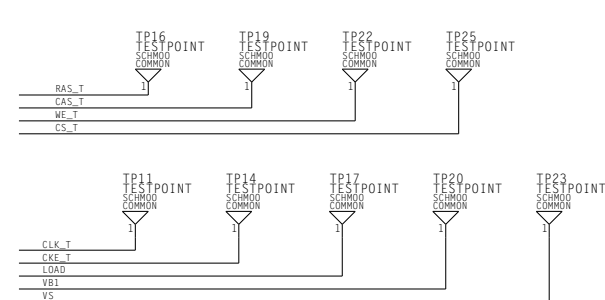
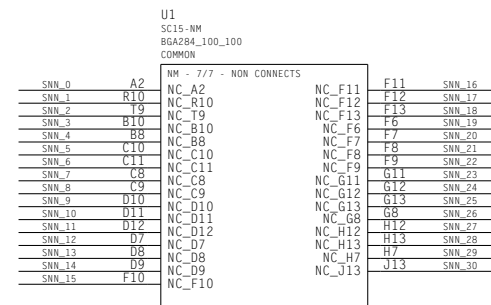
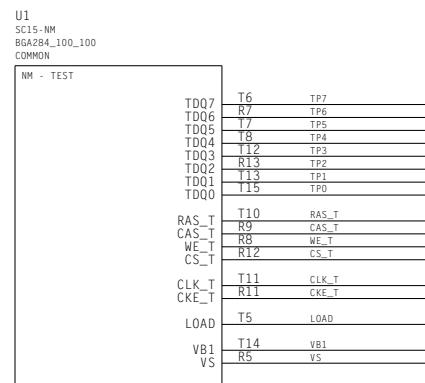

NVIDIA CORPORATION

2701 SAN TOMAS EXPRESSWAY  
SANTA CLARA, CA 95050, USA



ASSEMBLY BASE LEVEL GENERIC ONLY, COMMON & NO\_STUFF ASSEMBLY NOTES AND BDM NOT FINAL  
PAGE DETAIL Audio, SDCard & Interfaces

NV\_PN 600-80436-0000-100

ID e436 PAGE 3 OF 5  
NAME manoharc DATE 23-AUG-2005

ALL NVIDIA DESIGN SPECIFICATIONS, REFERENCE SPECIFICATIONS, REFERENCE BOARDS, FILES, DRAWINGS, DIAGNOSTICS, LISTS AND OTHER DOCUMENTS OR INFORMATION (TOGETHER AND SEPARATELY, "MATERIALS") ARE BEING PROVIDED "AS IS". THE MATERIALS MAY CONTAIN KNOWN AND UNKNOWN VIOLATIONS OR DEVIATIONS OF INDUSTRY STANDARDS AND SPECIFICATIONS. NVIDIA MAKES NO WARRANTIES, EXPRESSED, IMPLIED, STATUTORY OR OTHERWISE WITH RESPECT TO THE MATERIALS OR OTHERWISE, AND EXPRESSLY DISCLAIMS ALL IMPLIED WARRANTIES INCLUDING, WITHOUT LIMITATION, THE WARRANTIES OF DESIGN, OF NON-INFRINGEMENT, MERCHANTABILITY OR FITNESS FOR A PARTICULAR PURPOSE, OR ARISING FROM A COURSE OF DEALING, TRADE USAGE, TRADE PRACTICE, OR INDUSTRY STANDARDS.

# E436 SC15-NM Board

## Power Connector & Bypass Caps

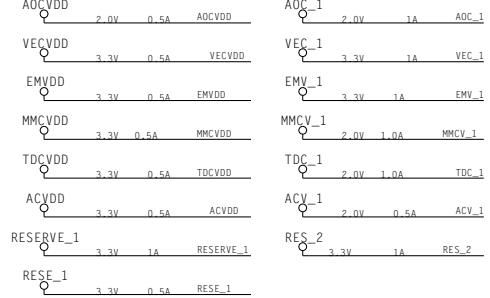
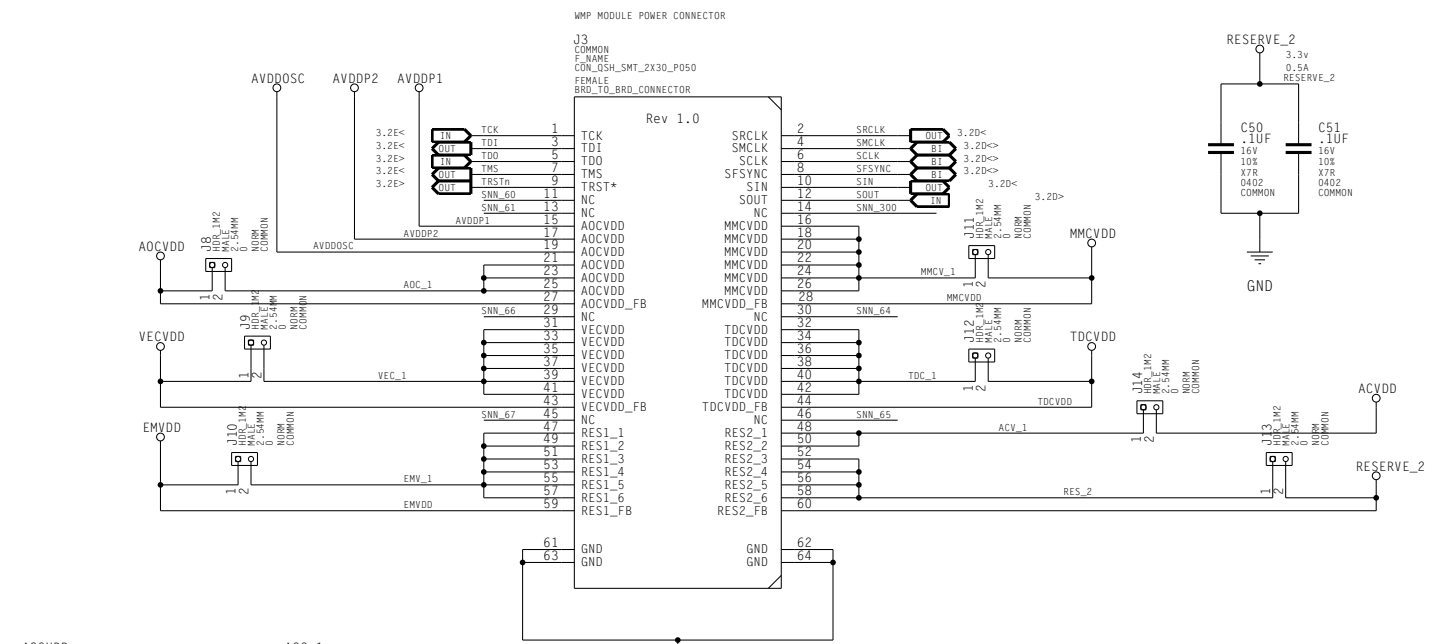

### Core Voltage Bypass Caps

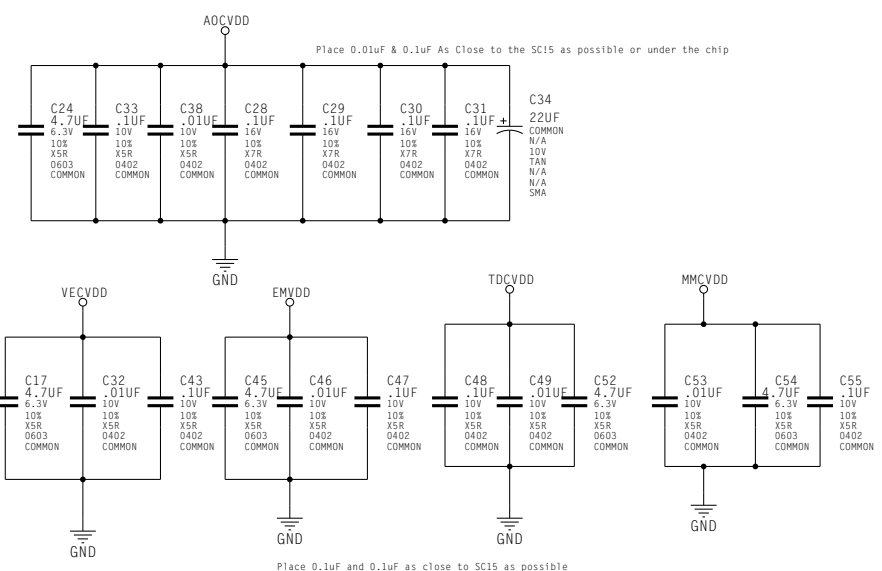

### Internal Memory Bypass Caps

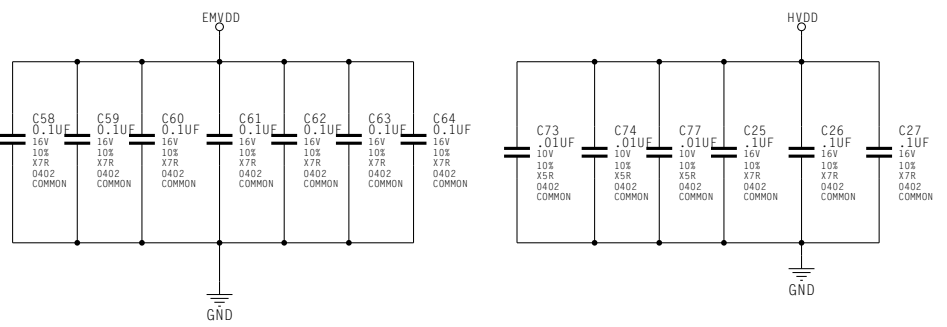

### SC15 Power pins

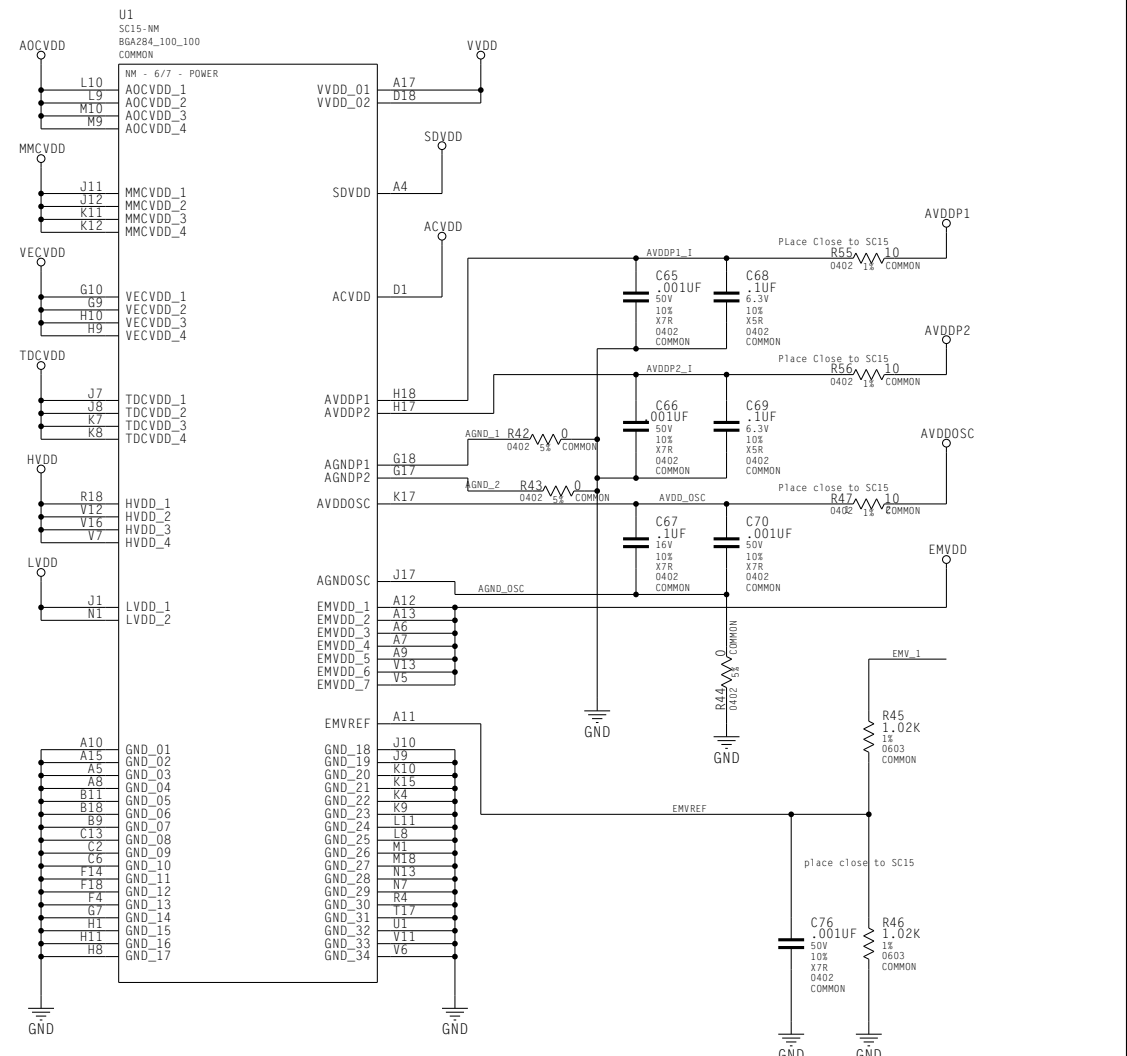

### I/O Bypass Caps

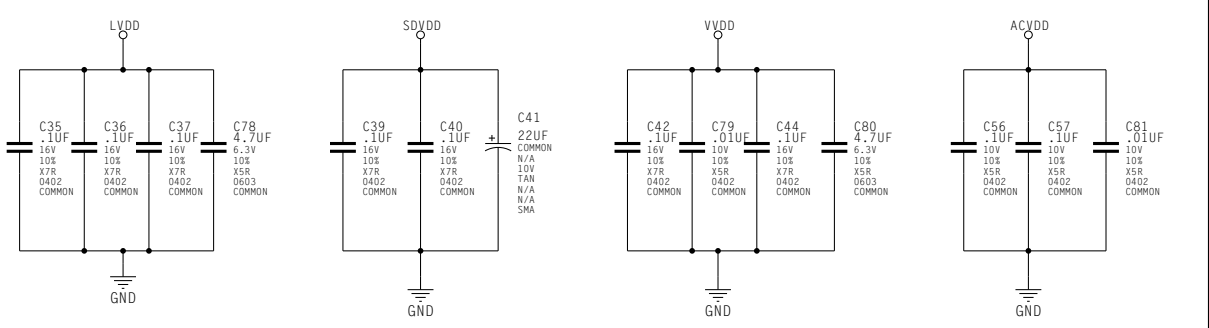

**NVIDIA CORPORATION**  
 2701 SAN TOMAS EXPRESSWAY  
 SANTA CLARA, CA 95050, USA

ASSEMBLY: BASE LEVEL GENERIC ONLY, COMMON & NO\_STUFF ASSEMBLY NOTES AND BDM NOT FINAL  
 PAGE DETAIL: Power supplies and Bypassing

NV_PN	600-80436-0000-100
ID	e436
NAME	manoharc
PAGE	4 OF 5
DATE	23-AUG-2005

ALL NVIDIA DESIGN SPECIFICATIONS, REFERENCE SPECIFICATIONS, REFERENCE BOARDS, FILES, DRAWINGS, DIAGNOSTICS, LISTS AND OTHER DOCUMENTS OR INFORMATION (TOGETHER AND SEPARATELY, "MATERIALS") ARE BEING PROVIDED "AS IS". THE MATERIALS MAY CONTAIN KNOWN AND UNKNOWN VIOLATIONS OR DEVIATIONS OF INDUSTRY STANDARDS AND SPECIFICATIONS. NVIDIA MAKES NO WARRANTIES, EXPRESSED, IMPLIED, STATUTORY OR OTHERWISE WITH RESPECT TO THE MATERIALS OR OTHERWISE, AND EXPRESSLY DISCLAIMS ALL IMPLIED WARRANTIES INCLUDING, WITHOUT LIMITATION, THE WARRANTIES OF DESIGN, OF NONINFRINGEMENT, MERCHANTABILITY OR FITNESS FOR A PARTICULAR PURPOSE, OR ARISING FROM A COURSE OF DEALING, TRADE USAGE, TRADE PRACTICE, OR INDUSTRY STANDARDS.

	A	B	C	D	E	F	G	H
1								
2								
3								
4								
5								

ASSEMBLY	BASE LEVEL GENERIC ONLY, COMMON & NO_STUFF ASSEMBLY NOTES AND BDM NOT FINAL
PAGE DETAIL	<edit here to insert page detail>

**NVIDIA CORPORATION**

2701 SAN TOMAS EXPRESSWAY  
SANTA CLARA, CA 95050, USA



NV_PN	600-80436-0000-100	
ID	e436	PAGE 5 OF 5
NAME	manoharc	DATE 23-AUG-2005

ALL NVIDIA DESIGN SPECIFICATIONS, REFERENCE SPECIFICATIONS, REFERENCE BOARDS, FILES, DRAWINGS, DIAGNOSTICS, LISTS AND OTHER DOCUMENTS OR INFORMATION (TOGETHER AND SEPARATELY, "MATERIALS") ARE BEING PROVIDED "AS IS". THE MATERIALS MAY CONTAIN KNOWN AND UNKNOWN VIOLATIONS OR DEVIATIONS OF INDUSTRY STANDARDS AND SPECIFICATIONS. NVIDIA MAKES NO WARRANTIES, EXPRESSED, IMPLIED, STATUTORY OR OTHERWISE WITH RESPECT TO THE MATERIALS OR OTHERWISE, AND EXPRESSLY DISCLAIMS ALL IMPLIED WARRANTIES INCLUDING, WITHOUT LIMITATION, THE WARRANTIES OF DESIGN, OF NONINFRINGEMENT, MERCHANTABILITY OR FITNESS FOR A PARTICULAR PURPOSE, OR ARISING FROM A COURSE OF DEALING, TRADE USAGE, TRADE PRACTICE, OR INDUSTRY STANDARDS.

	A	B	C	D	E	F	G	H
--	---	---	---	---	---	---	---	---